

# NAO<sup>6</sup>

## DATASHEET

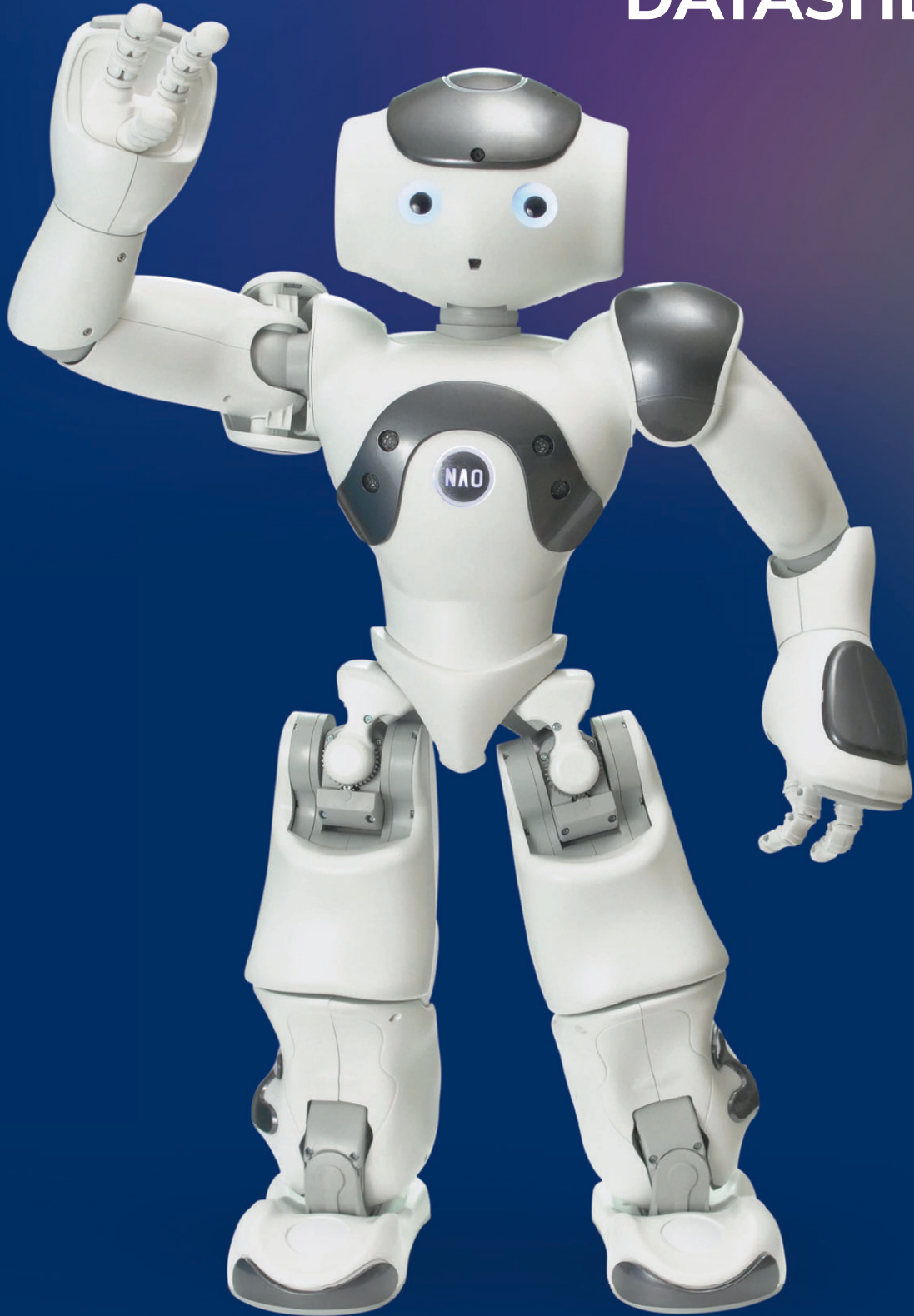

# NAO<sup>6</sup>

MODEL: H25600

## PHYSICAL CHARACTERISTICS

### GENERAL

Robot size (HxDxW)	574x311x275 mm / 22.6x12.2x10.8 in
Robot weight	5.48 kg / 12.08 lbs

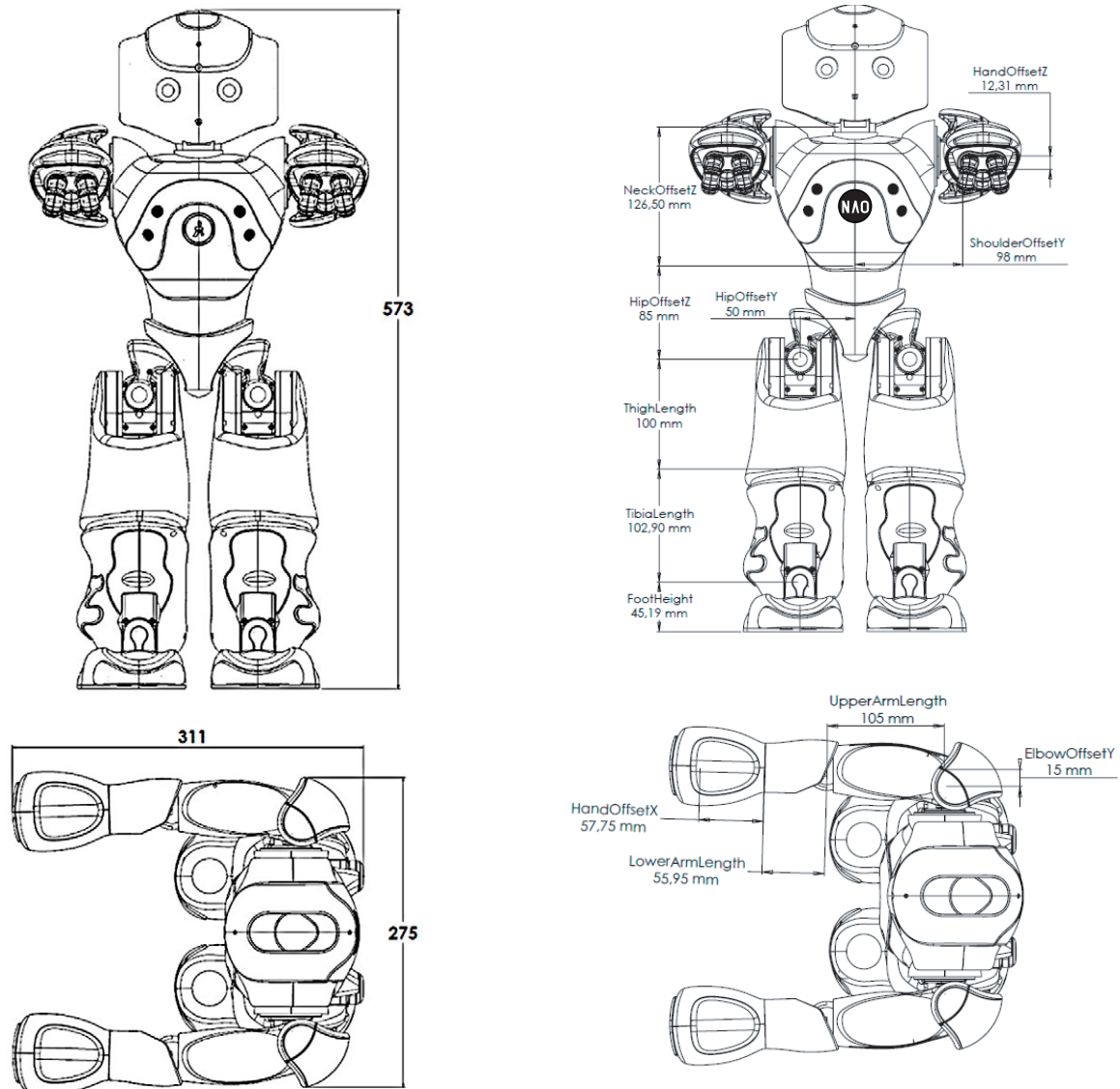

# NAO<sup>6</sup>

## POWER

### ROBOT

Input	24.8 V <sub>DC</sub> / 2.0 A Typ.
Working temperature	-5°C to 35°C 23°F to 95°F
IP rating	IPX0

### BATTERY

Type	Lithium-Ion
Nominal voltage/capacity	21.6 V / 2.9 Ah
Max charge voltage	25.2 V
Recommended charge current	1.8 A
Max charge / discharge current	2.1 A / 2.0 A
Energy	62.5 Wh
Working temperature	-20°C to 50°C -4°F to 122°F
Charging duration	90 min
Run time	60 min (Active use) 90 min (Normal use)

### CHARGER

	ADP-50ER	ADP-50MR
Input	100 to 240 V <sub>AC</sub> / 50-60 HZ / 1.2 A max	
Output	25.2 V <sub>DC</sub> / 2 A	
Casing dimensions	135 x 62 x 34 mm	155 x 67 x 37 mm
DC cable length	1.80 m	
Weight	400 g	500 g
Working temperature	-5 °C to 40 °C / 23 °F to 104 °F	

## BRAIN SYSTEM

### MOTHER BOARD

CPU	CPU processor	ATOM E3845
	Cache memory	2 MB
	Clock speed	1.91 GHz
RAM	4GB DDR3	
Flash memory	32GB eMMC	

## TRANSPORTATION

Carton Size (HxDxW)	29 x 36 x 57 cm 11.5 x 14.2 x 22.4 in
Carton Weight	8.5 kg / 17.6 lbs
HS Code	8471 41 00
Country of Origin	China

## CERTIFICATION

List of certified countries	Europe, China, USA, Canada, UK, Japan, Taiwan, Singapore, Australia & NZ, Israel, Qatar, Saudi Arabia, South Africa, Philippines
Main markings	CE, FCC, NRTL (cBvUs), Giteki, PSE, RCM, IMDA, NCC, BSMI, ...
Safety standards	IEC 62368-1:2014
EMC Class	Class A
Transportation	UN38.3, MSDS
EU Declaration of Conformity	<a href="https://www.maxtronics.com/en/conformity">https://www.maxtronics.com/en/conformity</a>

## CONNECTIVITY

### CONNECTION

Ethernet	1xRJ45 - 10/100/1000 BASE T
WIFI	IEEE 802.11a/b/g/n

### SOFTWARE

Open Nao	Embedded GNU/Linux Distribution based on Yocto
Architecture	x86
Programming	Embedded: C++ / Python

# NAO<sup>6</sup>

## HUMAN INTERACTION

### AUDIO

Loud Speakers	Left & Right	
	Diameter	40 mm
	Impedance	4 Ω
	Audio power	87 dB +/- 3 dB
	Freq range	up to ~20 kHz
Microphones	Input	2 W
	×4 omnidirectional on the head (A, B, C, D)	
	Sensitivity	-12dBV/PA @1KHZ
	Frequency range	100HZ to 10KHZ

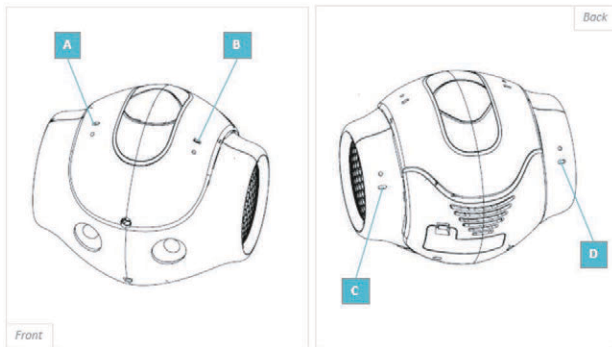

### LEDS

Placement	Quantity	Description
Tactile Head	12	16 White levels
Eyes	2×8	RGB FullColor
Ears	2×10	16 Blue levels
Chest button	1	RGB FullColor
Feet	2×1	RGB FullColor

### 2D CAMERA - FRAMERATES

	Top Camera	Bottom Camera
Resolution		
320×240 px	@15, 30 fps	@15, 30 fps
640×480 px	@15, 30 fps	@15, 30 fps
1280×960 px	@15, 30 fps	@10, 15 fps
1920×1080 px	@15, 30 fps	-
2560×1920 px	@15 fps	-

Note: The rate of the video stream will depend on the network and the video resolution chosen. All frame rates depend on the CPU usage. Values are measured with a CPU fully dedicated to image gathering.

### LANGUAGES

Text to speech	Arabic, Czech, Danish, Dutch, English, Finnish, French, German, Greek, Italian, & Automatic
speech	Japanese, Korean, Standard Mandarin, Taiwanese Mandarin, Norwegian,
Recognition	Polish, European Portuguese, Brazilian Portuguese, Spanish, Swedish, Russian, Turkish.

### 2D CAMERAS

Cameras	2 front of head	
Sensor model	OV5640	
Sensor type	SoC - CMOS Image Sensor	
Imaging array	Resolution	5 MP
	Size	1/4 in
	Active Pixels (H×V)	2592 x 1944
Sensitivity	Pixel size	1.4 x 1.4 μm
	Dynamic range	68 dB @8x gain
	Signal/Noise ratio (max)	36 dB
	Responsivity	600 mV/lux-sec
	Camera output	640 x 480 @30 fps
Output	Data Format	YUY & RGB
	Shutter type	Rolling Shutter/ frame exposure
View	Field of view	67.4° DFOV (56.3° HFOV, 43.7° VFOV)
	Focus range	10 cm ~ ∞ ≈ 4 in - ∞
	Focus type	Auto focus

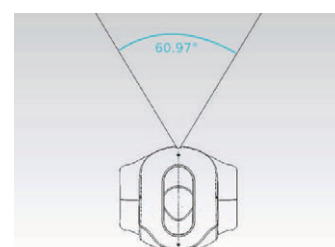
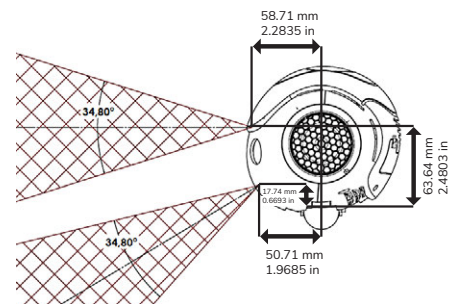

# NAO<sup>6</sup>

## ENVIRONMENT SENSORS

### INERTIAL UNIT

Gyrometer	1	
Axis		3
Precision		5%
Angular speed		500° /s approx.

IMU	1	
Axis		3
Precision		10%
Nominal acceleration		2 g approx.

### SONAR

Transmitters	2 on front
Receivers	2 on front
Frequency	40 kHz
Resolution	1 cm @50 cm
Detection Range	0.20 m to 0.80 m
Effective Cone	60°

### FORCE SENSITIVE RESISTORS (FSR)

Range	0 to 25 N
Location	4 in each foot
Sensitivity	40 g approx.

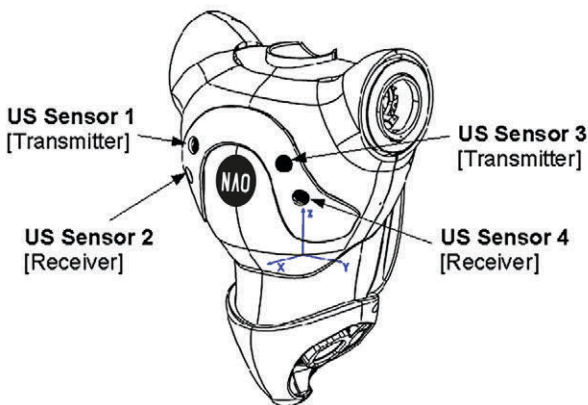
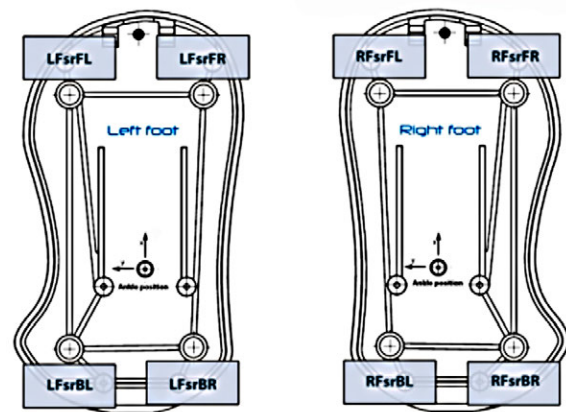

### BUTTONS & SENSORS

Chest Button	✓
Foot Bumper	✓
Tactile Head	✓
Tactile Hand	✓

# NAO<sup>6</sup>

## MOTION

### DEGREES OF FREEDOM

Head	2
Arm (in each)	5
Pelvis	1
Leg (in each)	5
Hand (in each)	1

### JOINT MOVEMENT ENCODERS

MRE (Magnetic Rotary Encoder)	36
	Using hall effect sensor technology
	Precision: 12 bits / 0.1°

### MOTOR SPECIFICATIONS

Motor type Brush DC Coreless

### POSITION OF MOTORS

		Gear Ratio	Motor type
Head joints	HeadYaw	150.27	3
	HeadPitch	173.22	3
Arm joints	ShoulderPitch	150.27	4
	ShoulderRoll	173.22	3
	ElbowYaw	150.27	3
	ElbowRoll	173.22	3
Hand joints	WristYaw	50.61	2
	Hand/ Fingers	36.24	2
Leg joints	HipYawPitch	201.3	1
	HipRoll	201.3	1
	HipPitch	130.85	5
	KneePitch	130.85	5
	AnklePitch	130.85	5
	AnkleRoll	201.3	1

For details of type and gear ratio, see below.

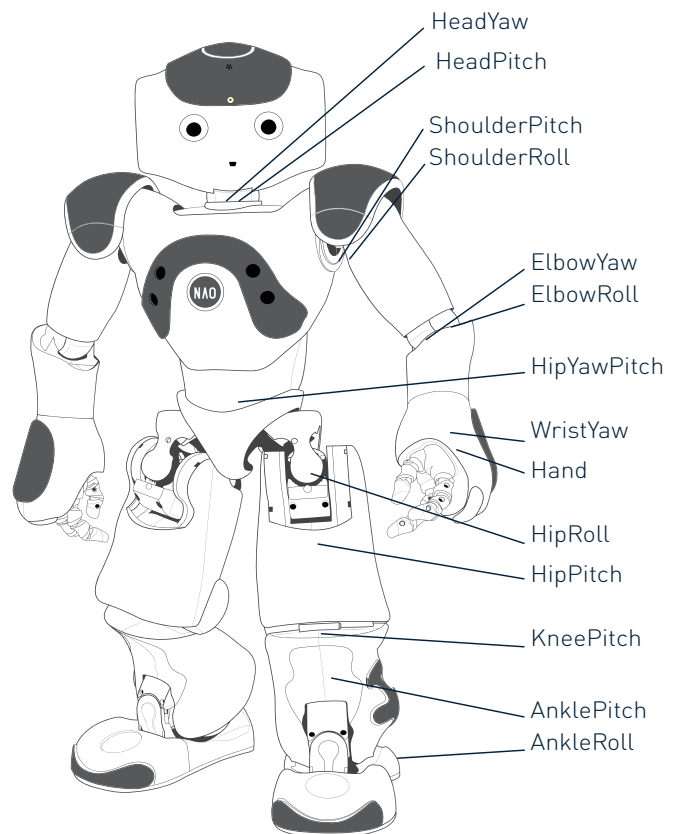

### MOTOR TYPE

	Motor type 1	Motor type 2	Motor type 3	Motor type 4	Motor type 5
Make	22NT82213P	17N88208E	16GT83210E	DCX 16S	22NT Z20
No load speed (rpm)	8700 ±10%	8400 ±12%	10700 ±10%	11400 ±10%	8700 ±10%
Stall torque (mNm)	65 ±8%	9.4 ±8%	14.3 ±8%	22.4 ±10%	65 ±10%
Continuous torque (mNm)	17.8 max	4.9 max	6.2 max	2.6 max	17.8 max

# NAO<sup>6</sup>

## TOOLS

### SDK



**Description** Software development kit for creating and controlling applications on NAO. Includes APIs and libraries (Python, C++), visual programming tools, simulation environment, and development documentation.

**Client** Windows, macOS, Linux

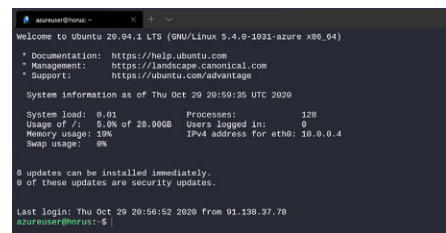

### Robot Setting



**Description** Desktop application for robot setup, configuration, and maintenance, including access to system information such as the installed NAOqi version.

**Client** Windows, macOS, Linux

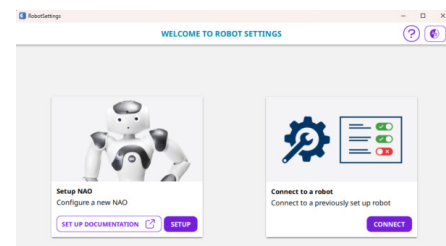

### Choregraphe



**Description** Desktop application for creating, testing, monitoring, and controlling NAO robot behaviors. Supports visual programming without coding, simulation, and integration of custom Python scripts.

**Client** Windows, macOS, Linux

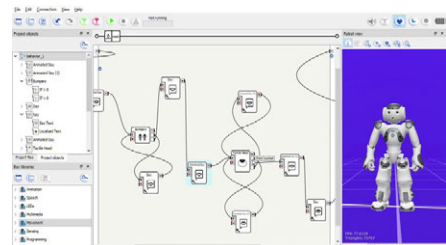

### NAO Activities



**Description** AI-powered platform for creating and running interactive educational, cognitive, and conversational activities on NAO without programming. Includes activity creation tools, QR code-based interactions, and a library of ready-to-use content for education and healthcare applications.

**Client** Web portal

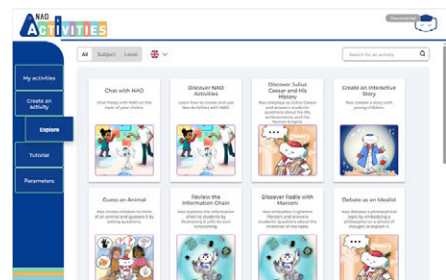

### Store Apps

**Description** Application marketplace for discovering, downloading, and managing software, behaviors, and extensions for NAO, including educational, research, and interaction-focused applications.

**Client** Web portal

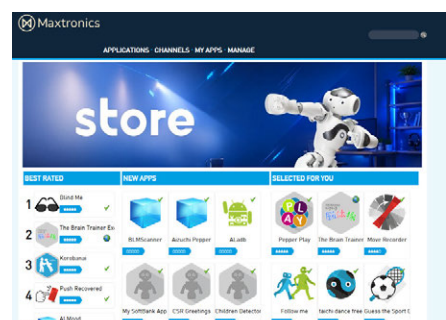



[www.maxtronics.com](http://www.maxtronics.com)

MAXTRONICS™, the MAXTRONICS logo™, NAO™, and the NAO logo™ are trademarks of MAXTRONICS ROBOTICS SAS (MAXTRONICS). The design of NAO™ is the property of MAXTRONICS. All images in this document are non-binding, may be subject to change, and are the property of MAXTRONICS.

Other trademarks, trade names, and logos mentioned in this document are the property of their respective owners or right holders, and their use is governed by the policies and conditions established by the latter. MAXTRONICS disclaims any proprietary interest in other marks and names.

Maxtronics Robotics SAS au capital de 100 000 € – 11 rue Camille Desmoulins – 92130 Issy-les-Moulineaux – France – RCS Nanterre n° 990 515 645